



Operation Manual

SA Vent

Models – Kona, Pali and Mistral



765 Westminster Street • Providence, Rhode Island 02903 • U.S.A.

Tel: (401) 273-3300 Fax: (401) 273-3328

www.equipex.com e-mail: service@equipex.com

IMPORTANT SAFEGUARDS

When using electrical appliances, basic safety precautions should always be followed, including the following:

1. Read all the instructions before use.
2. To avoid electric shock, **do not immerse the power cord, or any part of the unit**, in any liquid.
3. Unplug appliance from the electrical outlet when not in use, and before cleaning. Allow appliance to cool before installing or removing any parts or accessories, and before cleaning.
4. Do not operate any appliance with a damaged cord or plug, or if appliance should sustain damage, or malfunction in any way. In this event, return appliance to the nearest authorized service facility for examination, repair or adjustment.
5. The use of accessories and/or attachments not recommended by the appliance manufacturer may cause injury or damage to the appliance, and may void your warranty.
6. Do not use outdoors.
7. Do not allow the power cord to hang over the edge of a table or counter, or to be exposed to hot surfaces, as damage may occur.
8. Do not place appliance on or near a burner, or in a heated oven.
9. To disconnect an appliance, **first** turn all controls to the '**off**' position *then* unplug the power cord from the wall outlet.
10. Do not use appliance other than for its intended use.
11. SAVE THESE INSTRUCTIONS FOR LATER USE!

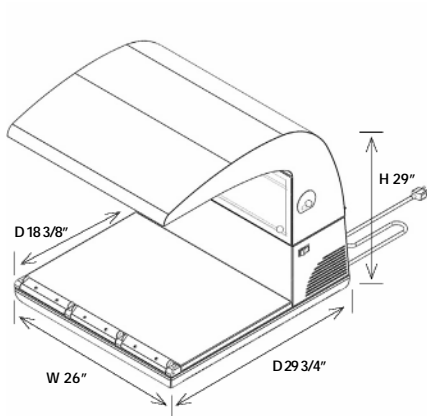

SAV-O MISTRAL

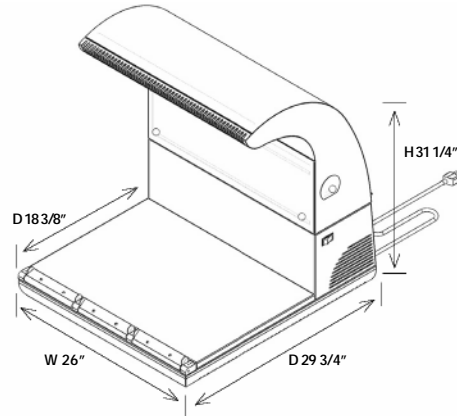

SAV-G PALI

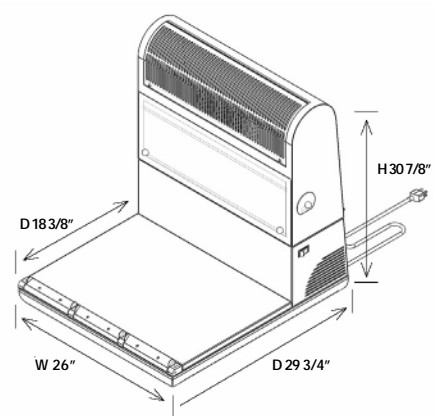

SAV-U KONA

SPECIFICATIONS

Patent Pending

MODEL	DIMENSIONS (HWD)	ELECTRICAL	NEMA PLUG	CAPACITY
SAV-O Mistral	29" x 26" x 29 3/4" Base 26"W x 18 3/8"D	115 VAC, 3.5 amps, single phase. 6 foot power cord with strain relief mounting, UL listed, grounded.	5-15P plug end.	Holds up to 150 lbs & dimensions up to 25 1/2" W by 18" D
SAV-G Pali	31 1/4" x 26" x 29 3/4" Base 26"W x 18 3/8"D			
SAV-U Kona	30 7/8" x 26" x 29 3/4" Base 26"W x 18 3/8"D			

CONSTRUCTION

- 304 Stainless Steel, #4 finish
- Filters removable from the front of the equipment:
 1. Angled baffle grease filter, cleanable and reusable
 2. Electrostatic material particulate filter to remove smaller particles in the air – disposable
 3. Activated charcoal filter to treat odors – disposable
- Removable grease collection cup

Designed & developed by

Ideas Well Done™

Installation: Unit must be installed on level surface.

Warranty: One year parts and labor (except filters)



SA Vent Operating Instructions

General:

The SA Vent is designed to improve the environment for kitchen staff and patrons by removing smoke, odors, moisture and grease laden vapors from the ambient air. It works with compact countertop cooking appliances such as convection ovens, toasters, Panini grills and griddles. The SA Vent unit operates from a standard 120V outlet, and draws 3.5A. It comes with a preinstalled NEMA 5-15P cord. The platform will hold equipment up to 150 lbs. and 25 ½" W x 18" D. The unit is equipped with interlock switches to insure that three all filters, and the front filter panel, are installed and correctly positioned in order to operate.

The air filtering system consists of the following three filters.

- Washable grease filter
- Disposable electrostatic particulate filter
- Disposable activated charcoal smoke filter

The Grease impinges upon the baffles and drains downward. Holes in the frame bottom divert the grease into a trough and to a container away from the fire danger area.

Installation:

The SA Vent is shipped assembled, except for the filters. Remove from packing materials and make sure the unit is complete and undamaged. The SA Vent must be installed on a level surface, away from sources of excessive heat and moisture. Insure that nothing is blocking the air intake cutouts that provide cooling of the motor, or the air exhaust ports.

The grease filter is installed at a 45-degree angle, to allow grease to flow freely down the baffles and through the drain holes. The grease channel below the filter is at a slight angle to allow the grease to run into the trap without pooling.

Operation:

First, make sure that the filters are correctly installed in the unit. Remove the front panel by grasping the knobs and sliding it upward until the bottom is free, then move the whole panel downward, while pulling the knobs gently towards you, until it is off the unit. Insure that the filters are all in place, and fully seated. The bottom filter is the activated charcoal filter, the center is the particulate filter, and the large metal filter on the top is the grease filter. The grease filter should be installed with the holes that are punched in one side facing toward the bottom of the unit, over the grease channel. Holes in the frame bottom divert the grease into a trough and to a container away from the fire danger area. Please note that the removable grease drawer must be in place. Reinstall the filter cover by reversing the removal procedure. Plug the unit into an appropriate outlet, and flip the lighted power switch, located on the right side of the unit, to the on position. Unit is now ready to filter grease-laden vapors.

Cleaning:

Use a cloth dampened slightly with a soap and water mixture to clean the stainless steel housing, upper grill cover, and the drip tray. Clean the SA Vent thoroughly at the end of each day. Failure to do so may cause hard to remove build up. The grease tray should be frequently checked to insure that it does not fill up and overflow. The two disposable filters should be removed and inspected, then replaced when they are too dirty to provide adequate air capture or if they become damaged in any way. The top grease filter should be frequently cleaned of grease, as it does not need to be replaced.

Filter Cleaning:

For moderate-use applications, run the grease filter through the dishwasher daily. For heavy use applications, presoaking in a detergent solution prior to dishwasher cleaning is commended. The electrostatic and carbon pleated filters are disposable.

DO NOT spray the unit with any cleaning liquid before unplugging it

DO NOT allow water to drip into the housing or around the electrical components

DO NOT immerse in water for cleaning



LIMITED WARRANTY

Your new **EQUIPEX** product is warranted to the original purchaser for a period of one year from the date of purchase.

This limited warranty is against defects from original factory imperfections in material and/or workmanship and includes labor for replacement of defective parts, provided repairs are performed by an authorized service agency. Our obligation under this warranty is limited to repairing or replacing any part or parts thereof. The CUSTOMER must inform the Service Agency of warranty coverage and provide a copy of the dated sales or delivery receipt BEFORE WARRANTY REPAIRS BEGIN. Replacement parts and accessories are warranted for ninety (90) days from the date of purchase when purchased separately and will be verified by dated sales receipt or packing slip for that item. All parts or accessories replaced under warranty must be returned to the Service Agency.

This warranty applies only to equipment under normal use and service in the U.S.A. and Canada. It does not apply to any item which has been repaired or altered in any way so as, in the judgment of EQUIPEX, to affect its reliability.

THE FOLLOWING ARE NOT COVERED UNDER WARRANTY:

1. Damage caused by abuse, misuse or dropping or other similar incidental damage caused by, or as a result of, customer failure to follow assembly, operation, cleaning, user maintenance or storage instructions.
2. Labor to replace inoperative parts such as bulbs, plugs or racks due to normal wear and tear or abuse.
3. Materials or labor to repair scratched, stained, chipped, pitted, dented or discolored surfaces, attachments or accessories.
4. Transportation charges to or from a service agency for repair of your machine. If you should have questions relating to this issue, please call **Equipex** at 1-800-649-7885.
5. Labor charges to install or test attachments or accessories, which are replaced for any reason.
6. SHIPPING DAMAGES. Visible and hidden damages are the responsibility of the freight carrier. The consignee must file the claim promptly against the carrier. KEEP ALL ORIGINAL CONTAINERS AND PACKAGING MATERIAL FOR CARRIER INSPECTION.
7. Products placed or stored in the equipment are not subject to this warranty and no responsibility is assumed thereof.

THIS WARRANTY IS GIVEN EXPRESSLY AND IN LIEU OF ALL OTHER WARRANTIES, EXPRESSED OR IMPLIED, FOR MERCHANTABILITY AND FOR FITNESS TOWARD A PARTICULAR PURPOSE AND CONSTITUTES THE ONLY WARRANTY MADE BY EQUIPEX, LLC. IT NEITHER ASSUMES, NOR AUTHORIZES ANY PERSON TO ASSUME FOR US, ANY OTHER LIABILITY IN CONNECTION WITH THE SALE OF THE SUBJECT EQUIPMENT.

For service, please call **EQUIPEX** at 1-800-649-7885, menu option # 3

765 Westminster Street • Providence, Rhode Island 02903 • U.S.A.

Tel: (401) 273-3300

Fax: (401) 273-3328

www.equipex.com

e-mail: service@equipex.com